

Instruction number
VICA-3x2_V1
Release date
26.07.2025



	VICA 3x2 cars 45 PANELS	MANUAL	WIND 28 m/s SNOW 1,6 kN/m²	Instruction number
				VICA-3x2_V1
				Release date
				26.07.2025

UK

Technical Information:

Average wind speed: 28 m/s

Snow load: 1.6 kN/m²

Important:

Before assembly, verify that the construction meets local requirements, considering environmental exposure specific to the location. Consultation with a licensed structural engineer is required

PL

Informacje techniczne:

Średnia prędkość wiatru: 28 m/s

Obciążenie śniegiem: 1,6 kN/m²

Ważne:

Przed montażem należy sprawdzić, czy konstrukcja spełnia wymagania lokalne, uwzględniając ekspozycję na warunki środowiskowe w danej lokalizacji. Wymagana konsultacja z uprawnionym projektantem budowlanym.

DE

Technische Informationen:

Durchschnittliche Windgeschwindigkeit: 28 m/s

Schneelast: 1,6 kN/m²

Wichtig:

Vor der Montage ist zu prüfen, ob die Konstruktion die örtlichen Anforderungen erfüllt, wobei die Umwelteinflüsse am jeweiligen Standort zu berücksichtigen sind. Eine Beratung durch einen zugelassenen Bauingenieur ist erforderlich.

FR

Informations techniques:

Vitesse moyenne du vent : 28 m/s

Charge de neige : 1,6 kN/m²

Important

Avant le montage, vérifiez que la construction répond aux exigences locales, en tenant compte de l'exposition aux conditions environnementales spécifiques à l'emplacement. Une consultation avec un ingénieur en structure agréé est requise.

IT

Informazioni tecniche:

Velocità media del vento: 28 m/s

Carico neve: 1,6 kN/m²

Importante:

Prima del montaggio, verificare che la struttura soddisfi i requisiti locali, tenendo conto dell'esposizione alle condizioni ambientali specifiche della posizione. È richiesta la consulenza di un ingegnere strutturale autorizzato.

CS

Technické informace:

Průměrná rychlost větru: 28 m/s

Sněhové zatížení: 1,6 kN/m²

Důležité:

Před montáží zkontrolujte, zda konstrukce splňuje místní požadavky s ohledem na vystavení konkrétním environmentálním podmínkám v dané lokalitě. Je vyžadována konzultace s autorizovaným stavebním inženýrem.

SK

Technické informácie:

Priemerná rýchlosť vetra: 28 m/s

Zaťaženie snehom: 1,6 kN/m²

Dôležité:

Pred montážou skontrolujte, či konštrukcia spĺňa miestne požiadavky, pričom zohľadnite vystavenie špecifickým environmentálnym podmienkam danej lokality. Je potrebná konzultácia s autorizovaným stavebným inžinierom.

	VICA 3x2 cars 45 PANELS	MANUAL	WIND 28 m/s SNOW 1,6 kN/m²	Instruction number
				VICA-3x2_V1
				Release date
				26.07.2025

ES

Información técnica:

Velocidad media del viento: 28 m/s

Carga de nieve: 1,6 kN/m²

Importante:

Antes del montaje, verifique que la construcción cumpla con los requisitos locales, teniendo en cuenta la exposición a las condiciones ambientales específicas de la ubicación. Se requiere la consulta con un ingeniero estructural autorizado.

PT

Informações técnicas:

Velocidade média do vento: 28 m/s

Carga de neve: 1,6 kN/m²

Importante:

Antes da montagem, verifique se a estrutura atende aos requisitos locais, considerando a exposição às condições ambientais específicas do local. É necessária a consulta com um engenheiro estrutural licenciado.

RO

Informații tehnice:

Viteza medie a vântului: 28 m/s

Încărcare de zăpadă: 1,6 kN/m²

Important:

Înainte de montaj, verificați dacă structura îndeplinește cerințele locale, luând în considerare expunerea la condițiile de mediu specifice locației. Este necesară consultarea unui inginer constructor autorizat.

NL

Technische informatie:

Gemiddelde windsnelheid: 28 m/s

Sneeuwbelasting: 1,6 kN/m²

Belangrijk:

Controleer vóór de montage of de constructie voldoet aan de lokale vereisten, rekening houdend met de blootstelling aan specifieke omgevingsomstandigheden op de locatie. Overleg met een erkende bouwkundig ingenieur is vereist.

SV

Teknisk information:

Genomsnittlig vindhastighet: 28 m/s

Snölast: 1,6 kN/m²

Viktigt:

Innan montering, kontrollera att konstruktionen uppfyller lokala krav med hänsyn till exponering för miljöförhållanden på platsen. Rådgör med en behörig byggnadsingenjör.

HU

Műszaki információk:

Átlagos szélesség: 28 m/s

Hóterhelés: 1,6 kN/m²

Fontos:

A szerelés előtt ellenőrizze, hogy a szerkezet megfelel-e a helyi követelményeknek, figyelembe véve a helyi környezeti feltételeket. Konzultáció egy engedéllyel rendelkező építési mérnökkel szükséges.

EL

Τεχνικές πληροφορίες:

Μέση ταχύτητα ανέμου: 28 m/s

Φορτίο χιονιού: 1,6 kN/m²

Σημαντικό:

Πριν από τη συναρμολόγηση, βεβαιωθείτε ότι η κατασκευή πληροί τις τοπικές απαιτήσεις, λαμβάνοντας υπόψη την έκθεση στις περιβαλλοντικές συνθήκες της συγκεκριμένης τοποθεσίας. Απαιτείται διαβούλευση με εξουσιοδοτημένο πολιτικό μηχανικό.

Instruction number
VICA-3x2_V1
Release date
26.07.2025

STEP 1

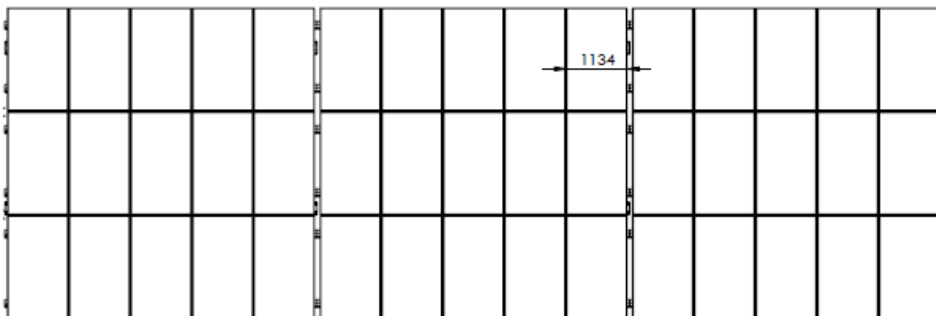
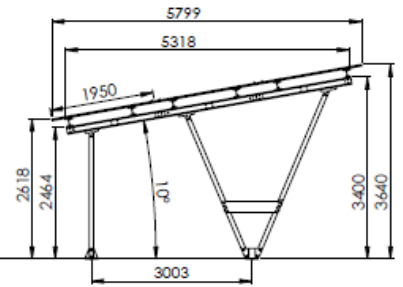
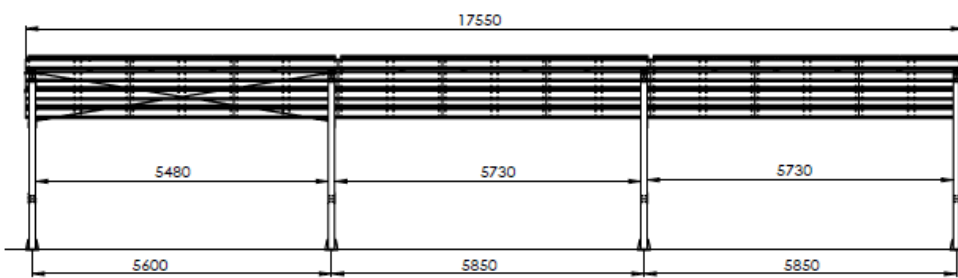
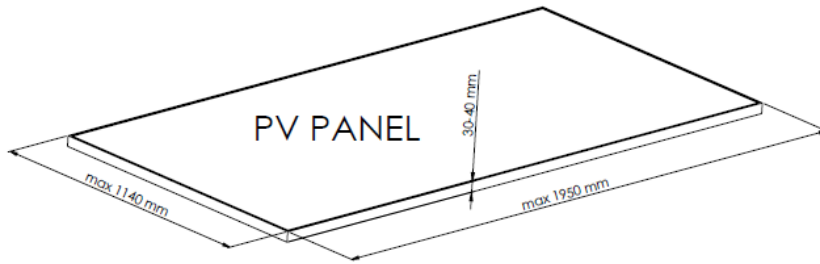

	VICA 3x2 cars 45 PANELS	MANUAL	WIND 28 m/s SNOW 1,6 kN/m²	Instruction number
				VICA-3x2_V1
				Release date
				26.07.2025

STEP2



Foundation construction manual.

Concrete of class B20/25

Foundation in accordance with the technical design.

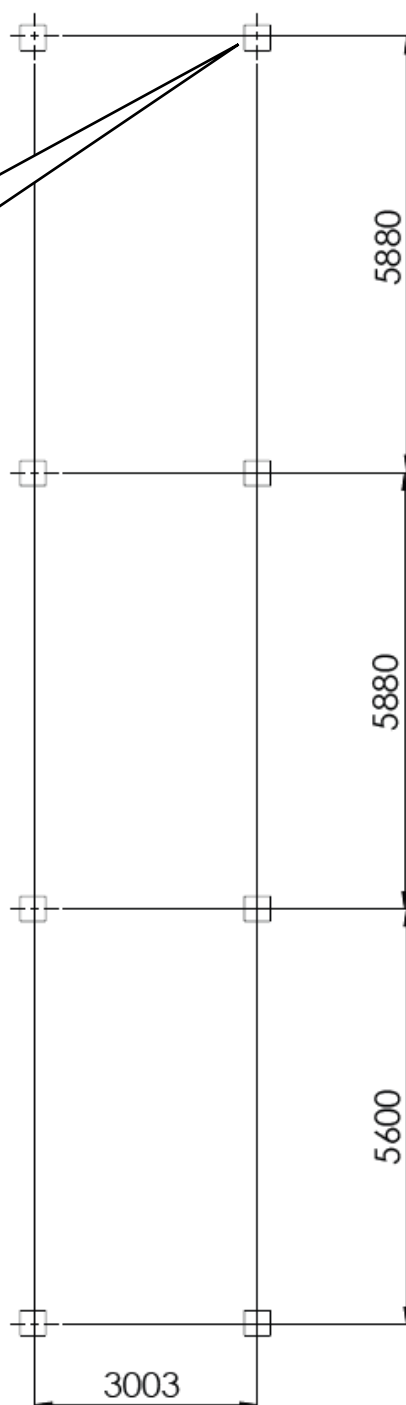

	VICA 3x2 cars 45 PANELS	MANUAL	WIND 28 m/s SNOW 1,6 kN/m²	Instruction number
				VICA-3x2_V1
				Release date
				26.07.2025





STEP 3



A 24 mm

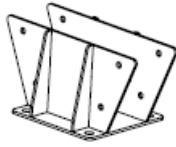
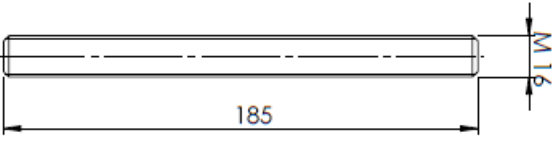

r-ker-II RAWLPLUG

1	CAR_IV_ST01		Not included in the standard set
2	CAR_IV_ST02		
3	Threaded rod M16x185 8.8		
4	DIN 125 A17		
5	DIN 127 M16		
6	DIN 934 M16		

Instruction number
VICA-3x2_V1
Release date
26.07.2025

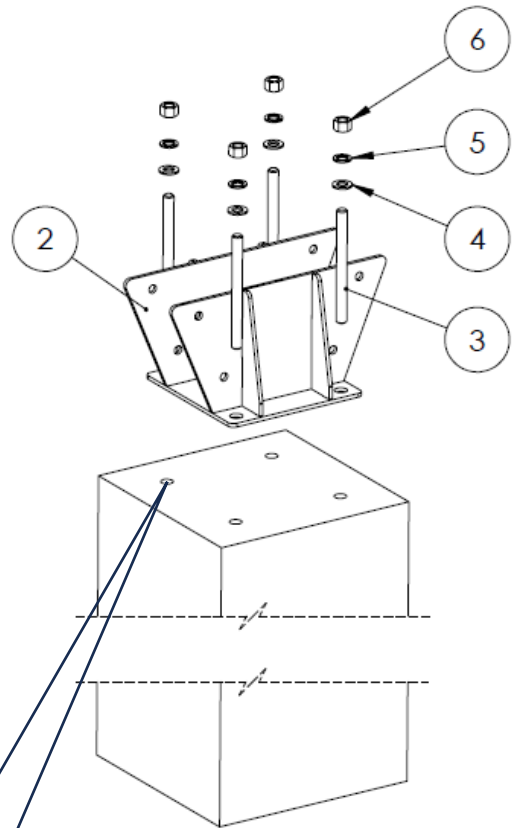
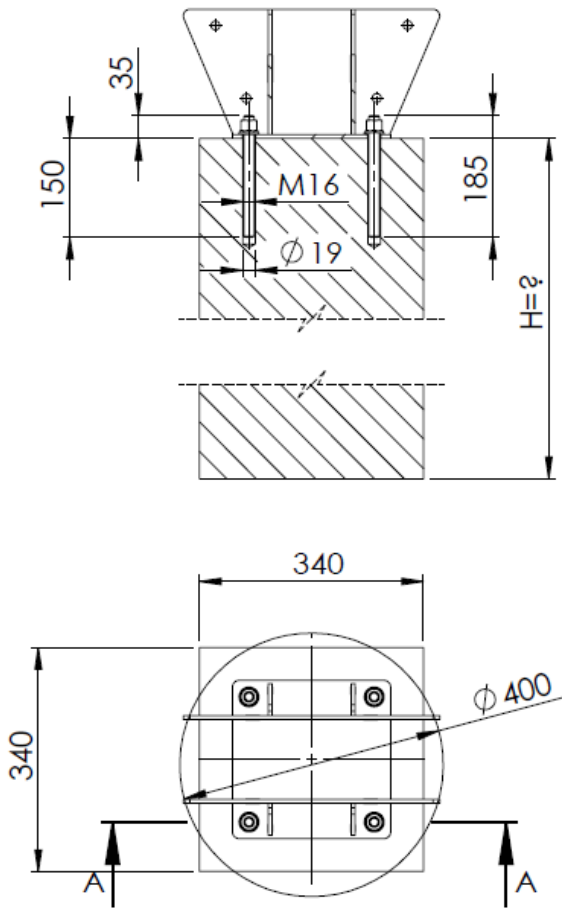

Instruction number
VICA-3x2_V1
Release date
26.07.2025

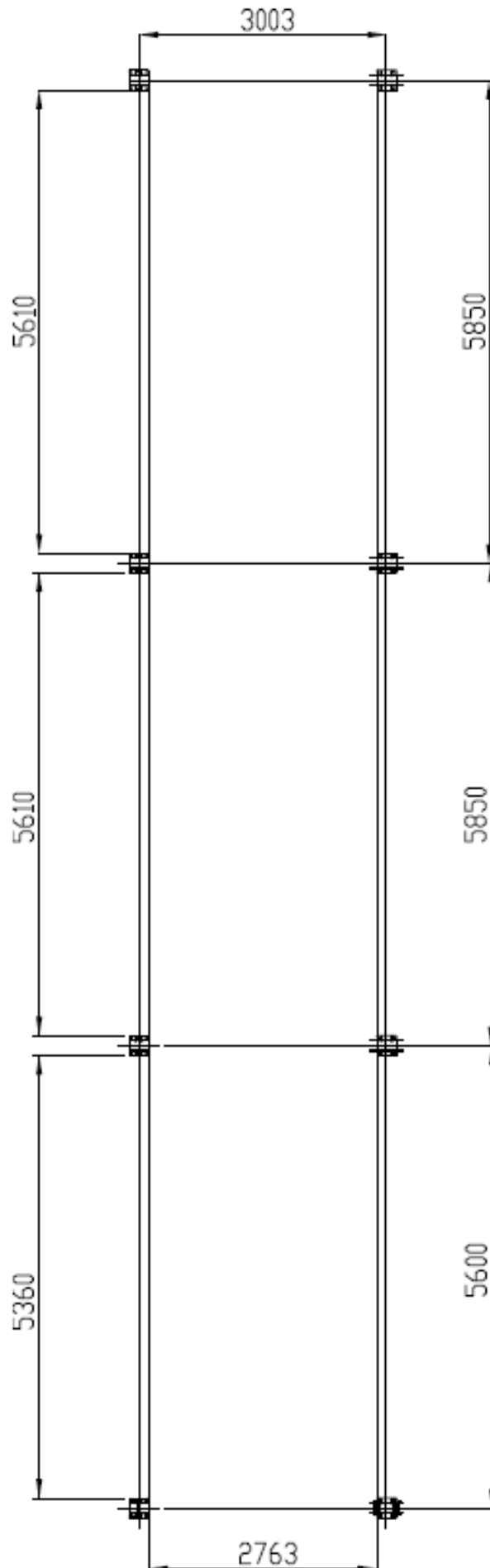

Instruction number
VICA-3x2_V1
Release date
26.07.2025

STEP 4



A 19 mm

1	CAR_IV_S02	
2	CAR_IV_S03	
3	CAR_IV_T01	
4	M12x150 DIN 931	
5	M12 DIN 125	
6	M12 DIN 127	
7	M12 DIN 934	

Instruction number
VICA-3x2_V1
Release date
26.07.2025

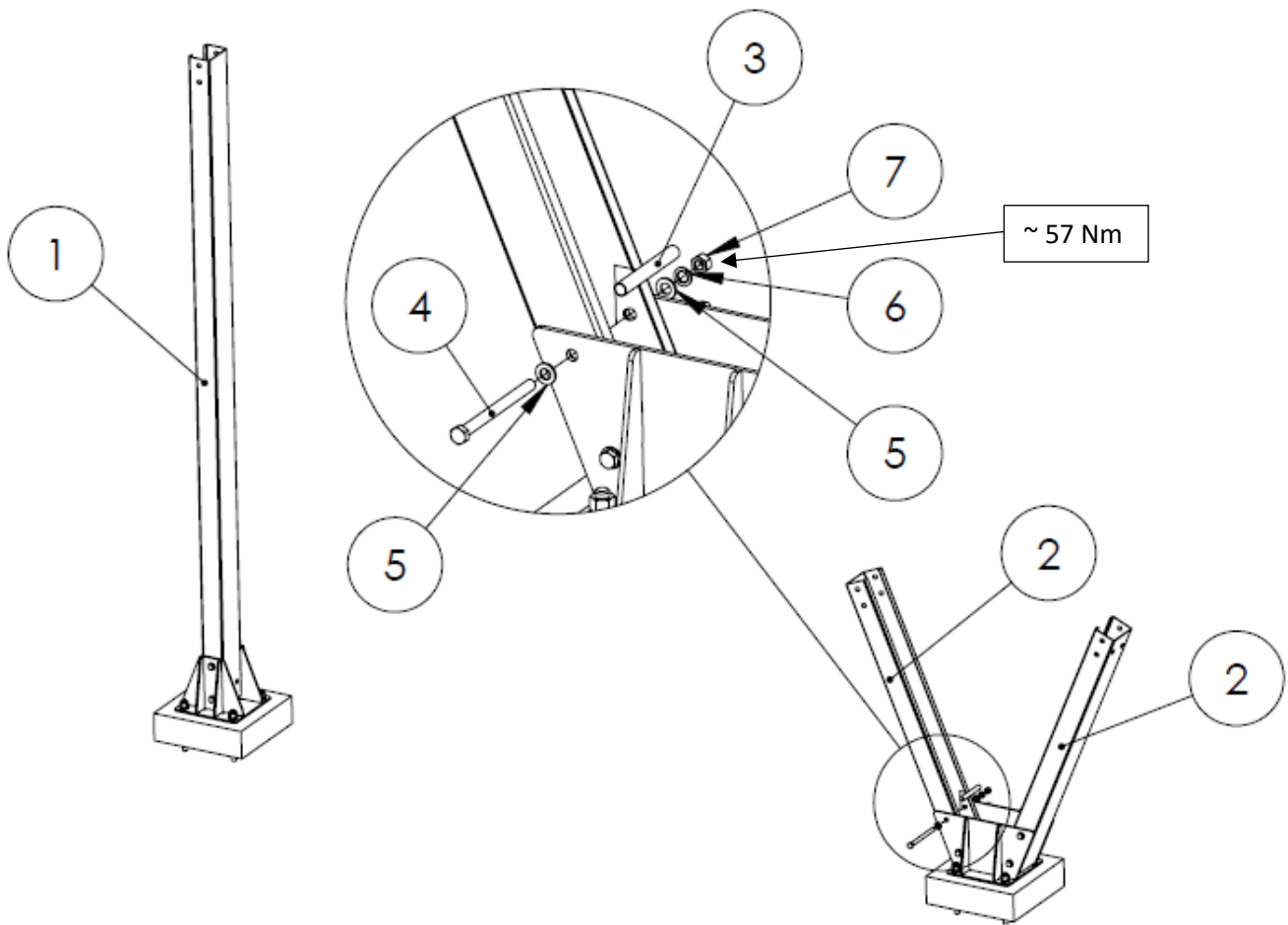

Instruction number
VICA-3x2_V1
Release date
26.07.2025

STEP 5

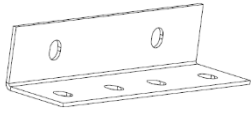
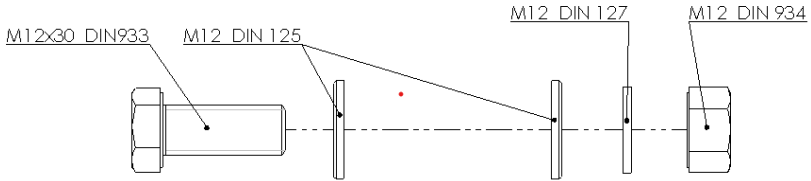

A 19 mm

<p>1</p>	<p>CAR_IV_L01</p>	
<p>2</p>	<p>SET 1</p>	

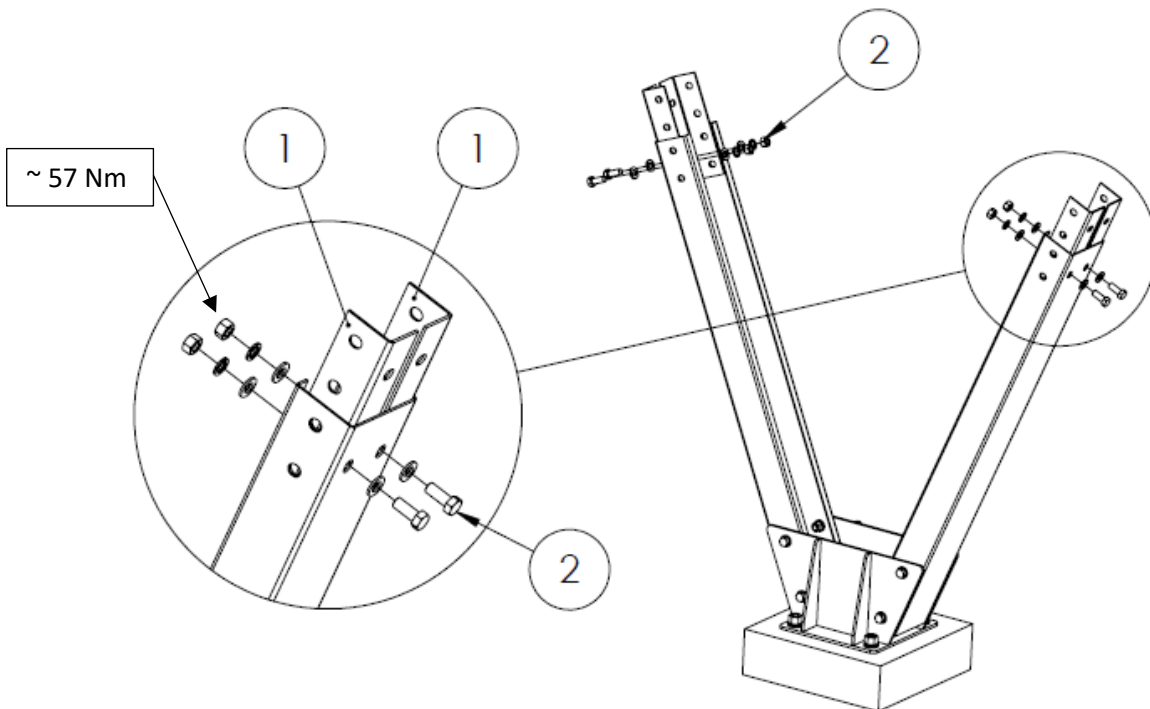



	VICA 3x2 cars 45 PANELS	MANUAL	WIND 28 m/s SNOW 1,6 kN/m²	Instruction number
				VICA-3x2_V1
				Release date
				26.07.2025

STEP 6

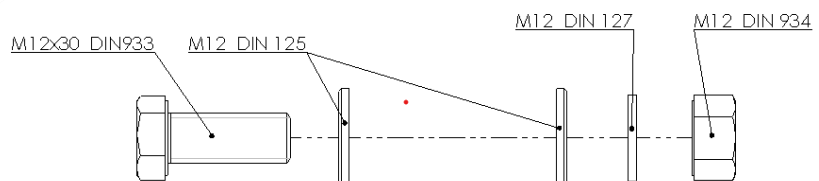

A 19 mm

1	CAR_IV_S02	
2	CAR_IV_S01	
3	CAR_IV_L02	
4	SET 1	

Instruction number
VICA-3x2_V1
Release date
26.07.2025

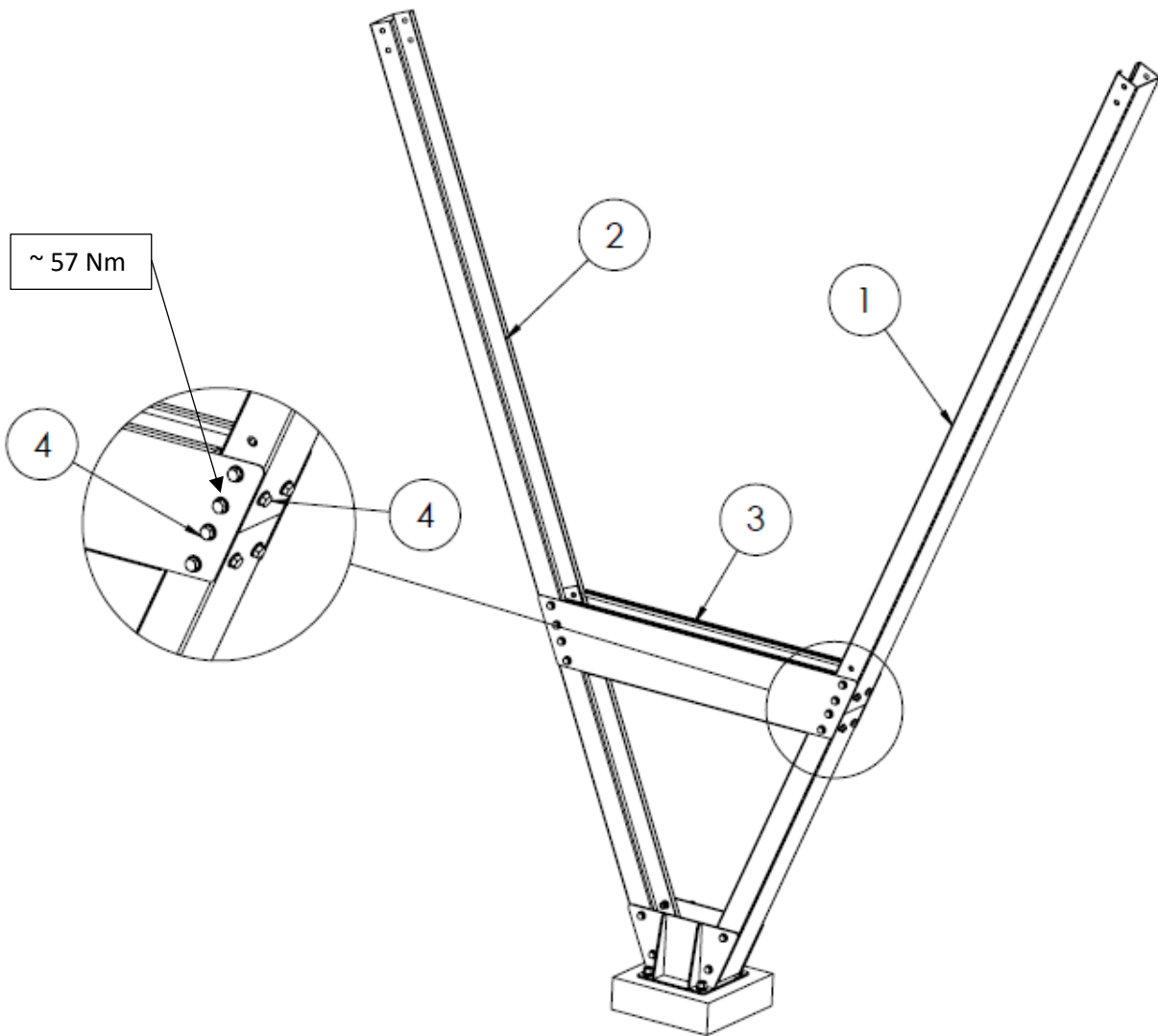

	VICA 3x2 cars 45 PANELS	MANUAL	WIND 28 m/s SNOW 1,6 kN/m2	Instruction number
				VICA-3x2_V1
				Release date
				26.07.2025

STEP 7

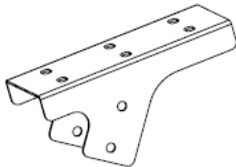
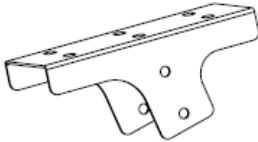
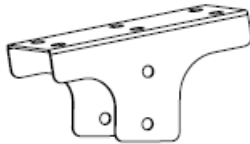
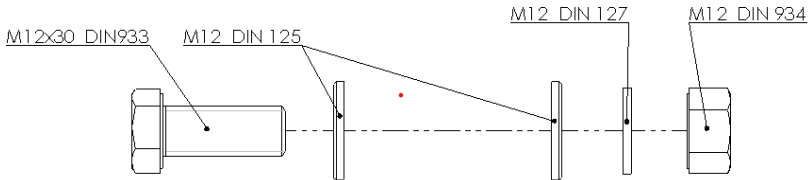

A 19 mm

1	CAR_IV_W01	
2	CAR_IV_W02	
3	CAR_IV_W03	
4	SET 1	 <p>M12x30 DIN933 M12 DIN 125 M12 DIN 127 M12 DIN 934</p>

Instruction number
VICA-3x2_V1
Release date
26.07.2025

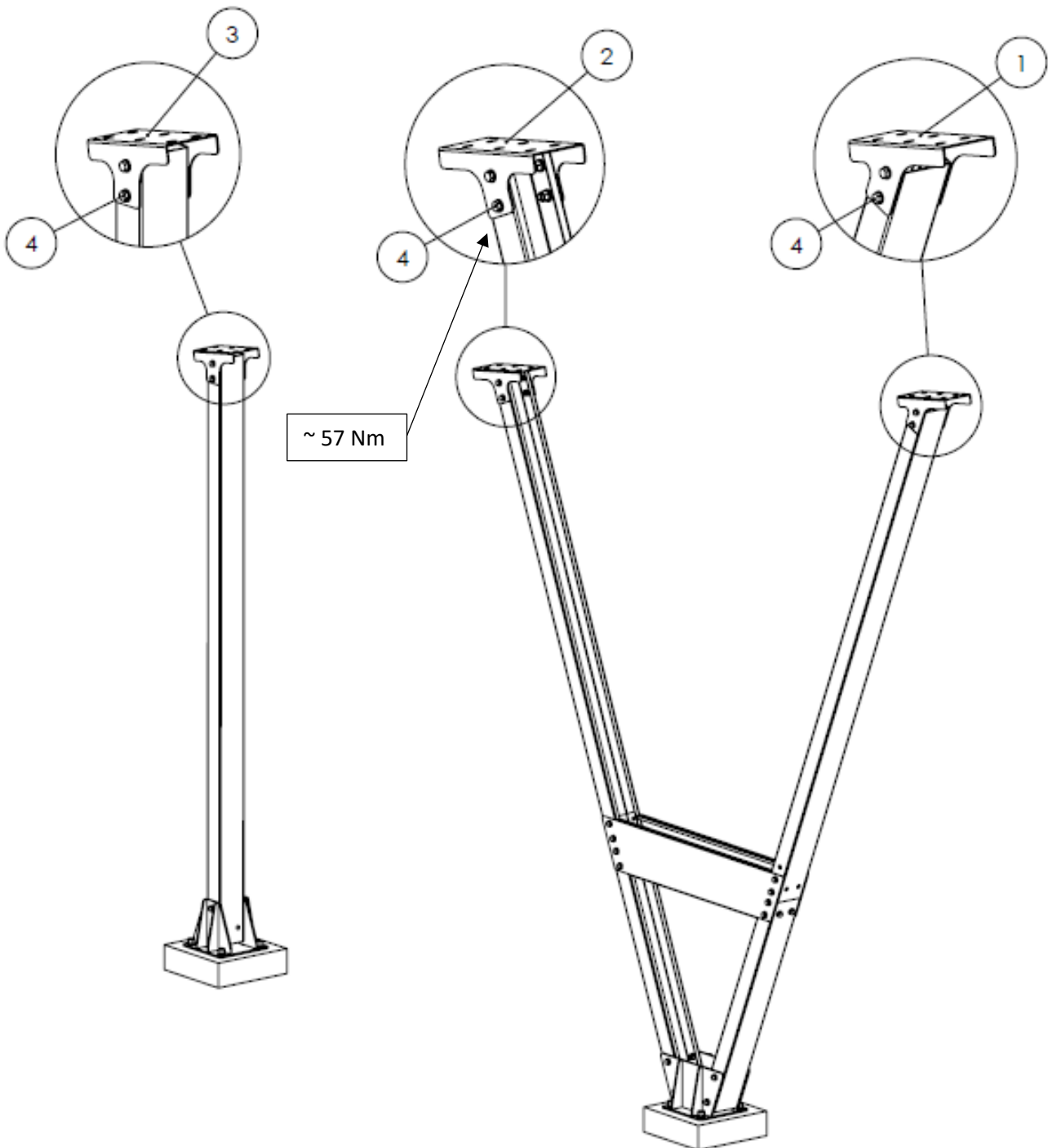

	VICA 3x2 cars 45 PANELS	MANUAL	WIND 28 m/s SNOW 1,6 kN/m2	Instruction number
				VICA-3x2_V1
				Release date
				26.07.2025

STEP 8



A 19 mm

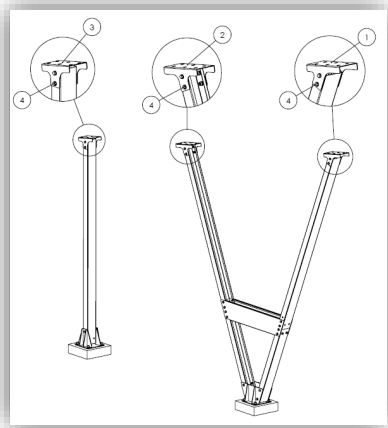

STEP 7

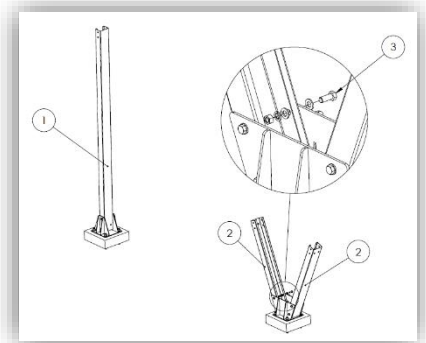

STEP 4

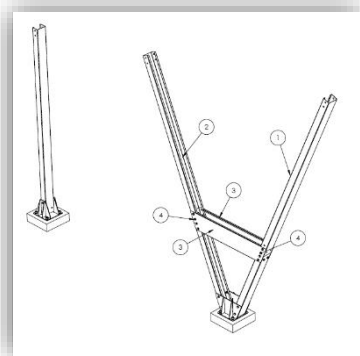
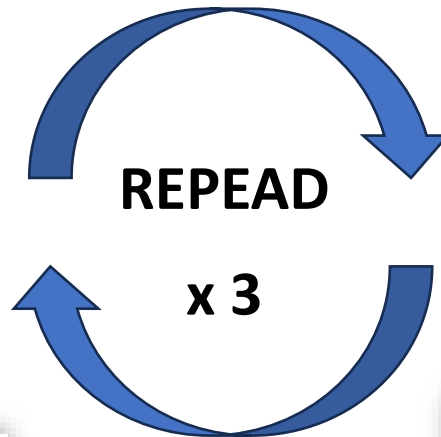

STEP 6

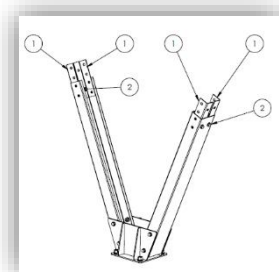

STEP 5

Instruction number
VICA-3x2_V1
Release date
26.07.2025



	VICA 3x2 cars 45 PANELS	MANUAL	WIND 28 m/s SNOW 1,6 kN/m²	Instruction number
				VICA-3x2_V1
				Release date
				26.07.2025

STEP 9

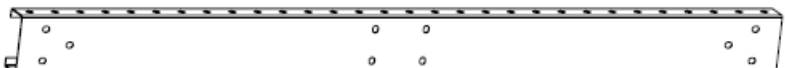
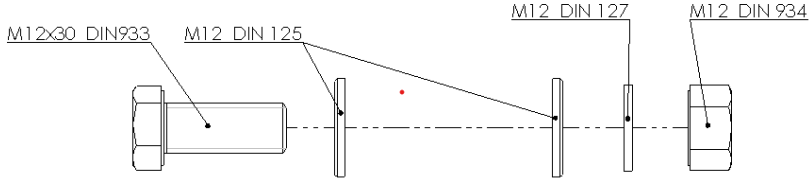
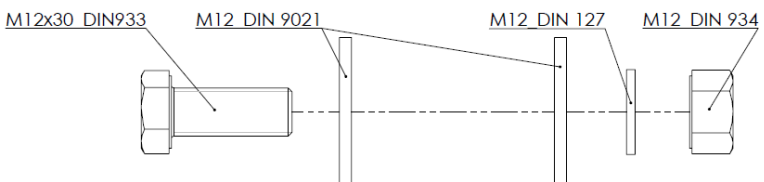

A 19 mm

1	CAR_IV_R02	
2	CAR_IV_R01	
3	SET 1	 <p>M12x30 DIN933 M12 DIN 125 M12 DIN 127 M12 DIN 934</p>
4	SET 2	 <p>M12x30 DIN933 M12 DIN 9021 M12 DIN 127 M12 DIN 934</p>

Instruction number
VICA-3x2_V1
Release date
26.07.2025

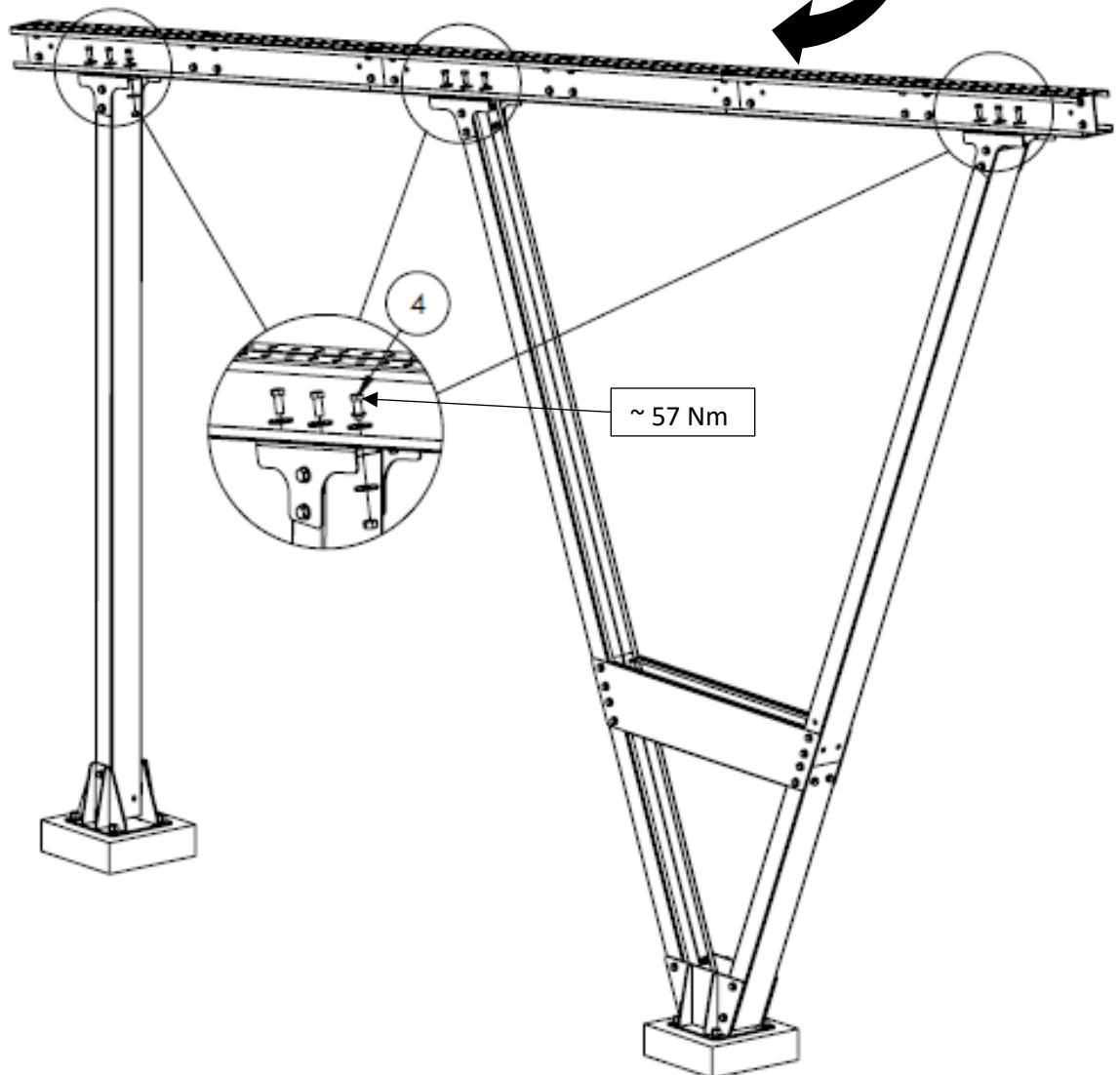
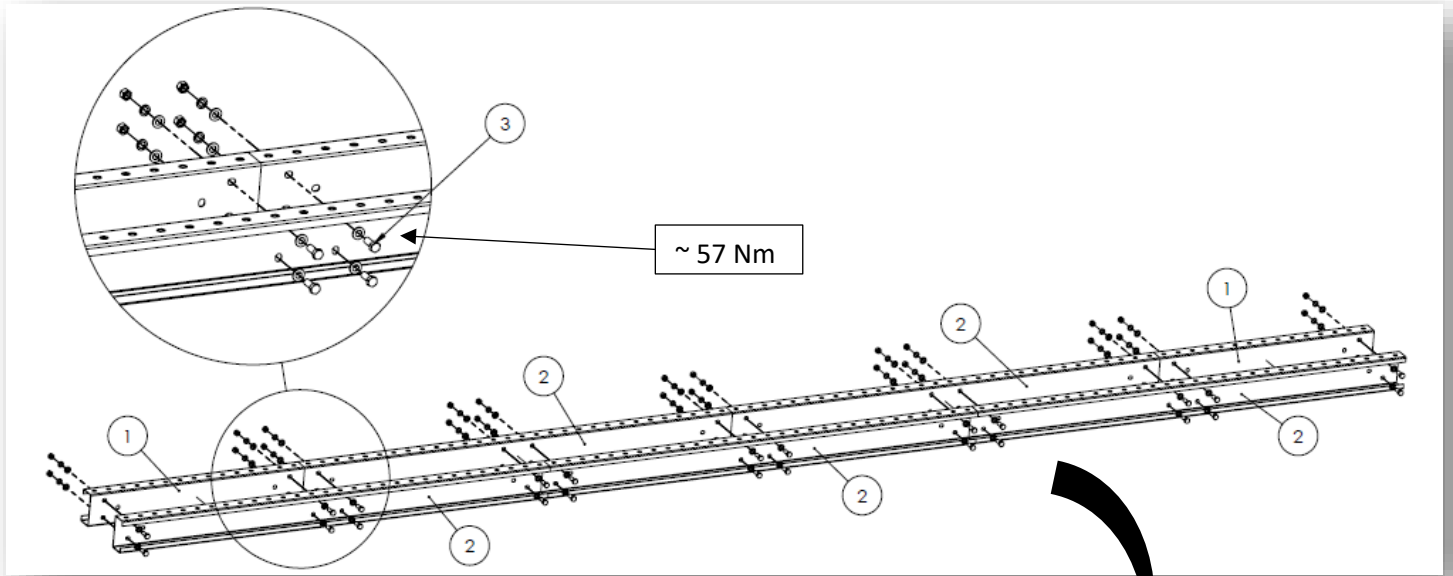

	VICA 3x2 cars 45 PANELS	MANUAL	WIND 28 m/s SNOW 1,6 kN/m²	Instruction number
				VICA-3x2_V1
				Release date
				26.07.2025

STEP 9



A 19 mm

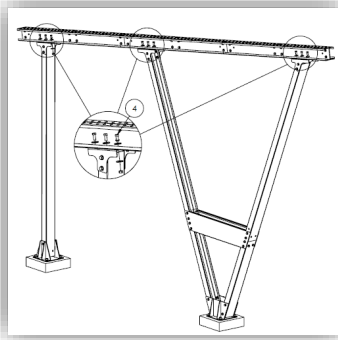

STEP 8

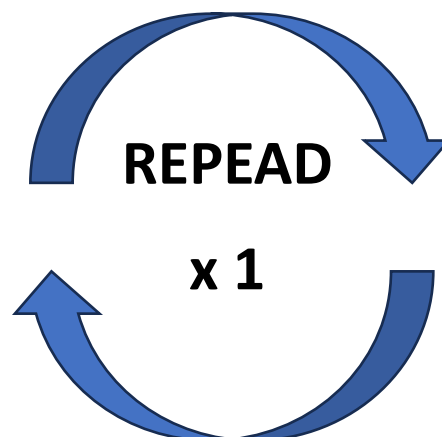

Instruction number
VICA-3x2_V1
Release date
26.07.2025





	VICA 3x2 cars 45 PANELS	MANUAL	WIND 28 m/s SNOW 1,6 kN/m²	Instruction number
				VICA-3x2_V1
				Release date
				26.07.2025

STEP 10

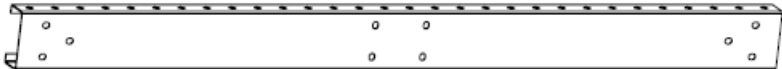
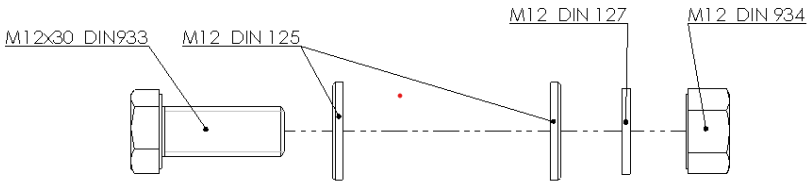
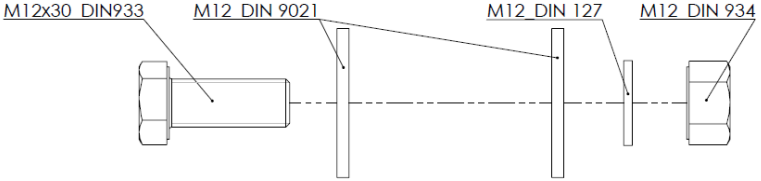

A 19 mm

1	CAR_IV_R02	
2	CAR_IV_R01	
3	SET 1	 <p>M12x30 DIN933 M12 DIN 125 M12 DIN 127 M12 DIN 934</p>
4	SET 2	 <p>M12x30 DIN933 M12 DIN 9021 M12 DIN 127 M12 DIN 934</p>
5	CAR_IV_WZ02	

Instruction number
VICA-3x2_V1
Release date
26.07.2025

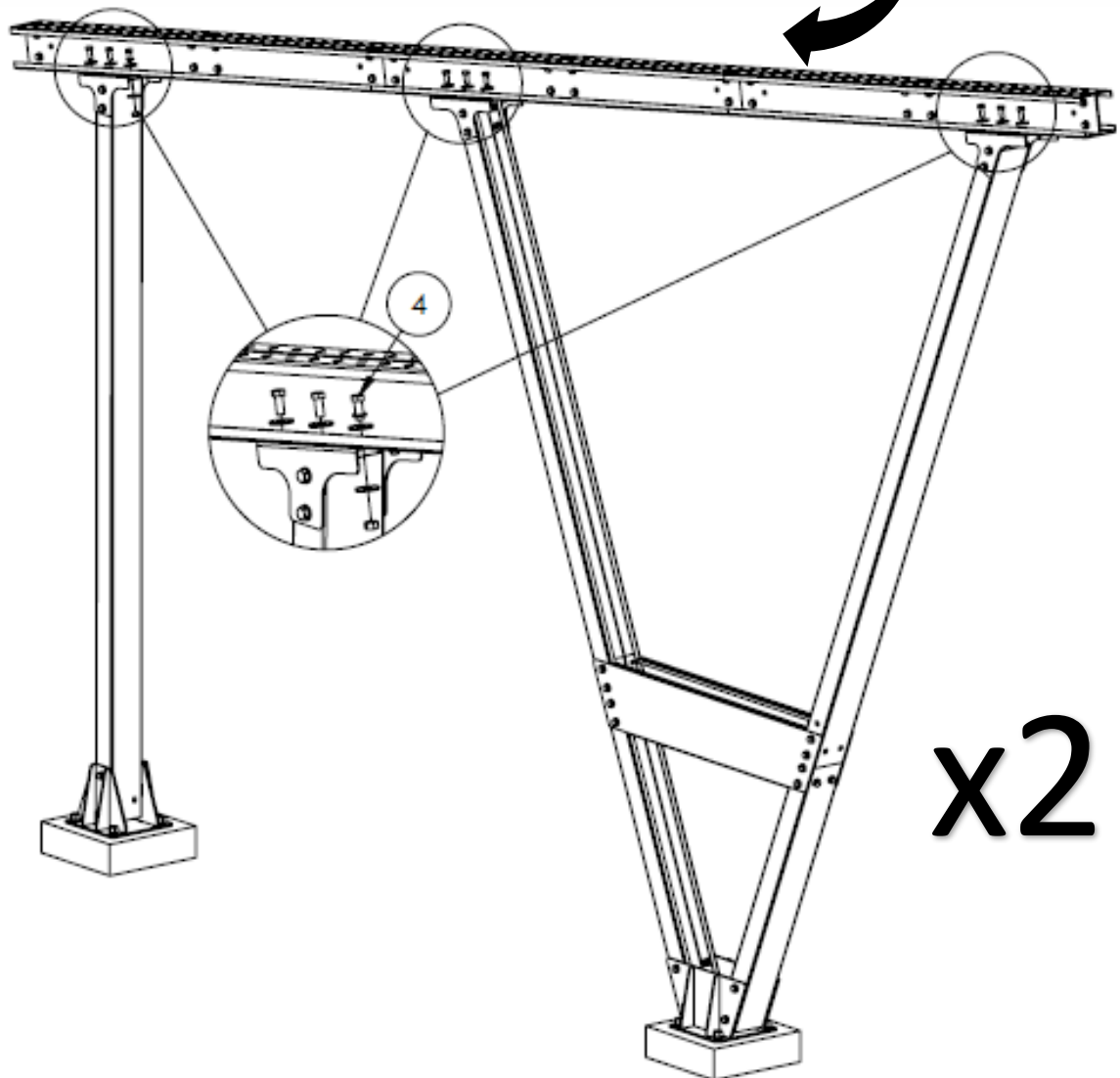
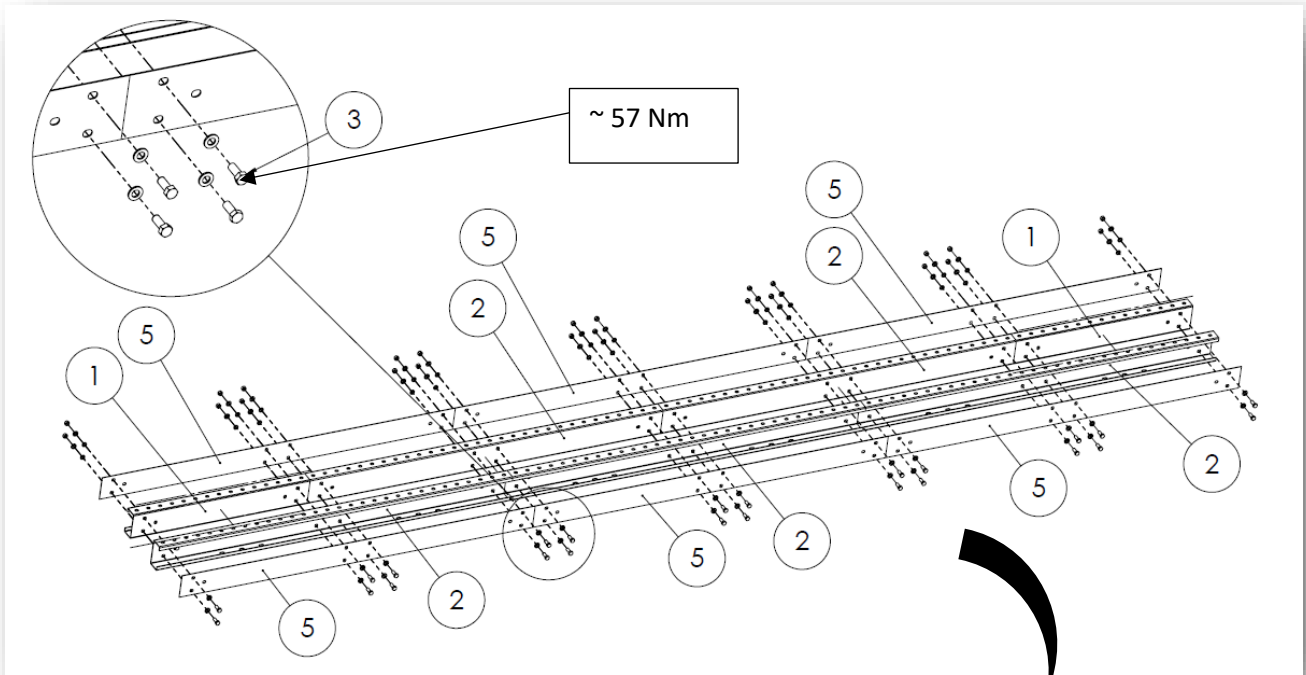

Instruction number
VICA-3x2_V1
Release date
26.07.2025



	VICA 3x2 cars 45 PANELS	MANUAL	WIND 28 m/s SNOW 1,6 kN/m2	Instruction number
				VICA-3x2_V1
				Release date
				26.07.2025

STEP 11

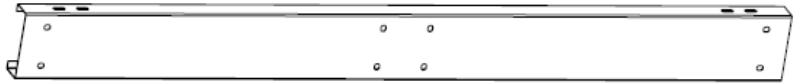
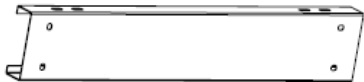
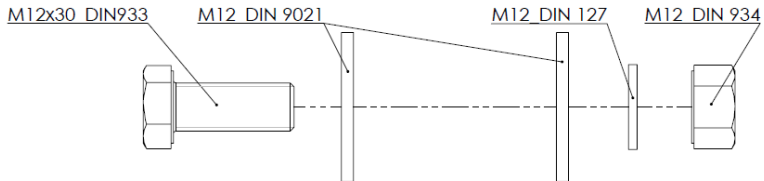
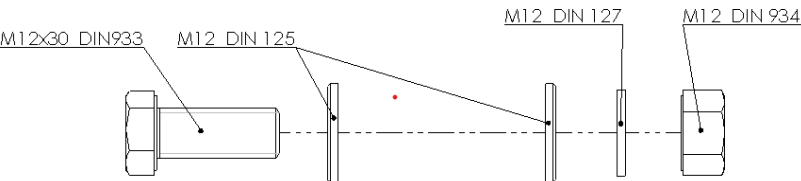
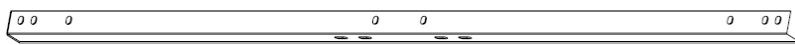

A 19 mm

1	CAR_IV_P01	
2	CAR_IV_P02	
3	SET 2	 <p>M12x30 DIN933 M12 DIN 9021 M12 DIN 127 M12 DIN 934</p>
4	SET 1	 <p>M12x30 DIN933 M12 DIN 125 M12 DIN 127 M12 DIN 934</p>
5	CAR_IV_WZ01_v1	

Instruction number
VICA-3x2_V1
Release date
26.07.2025

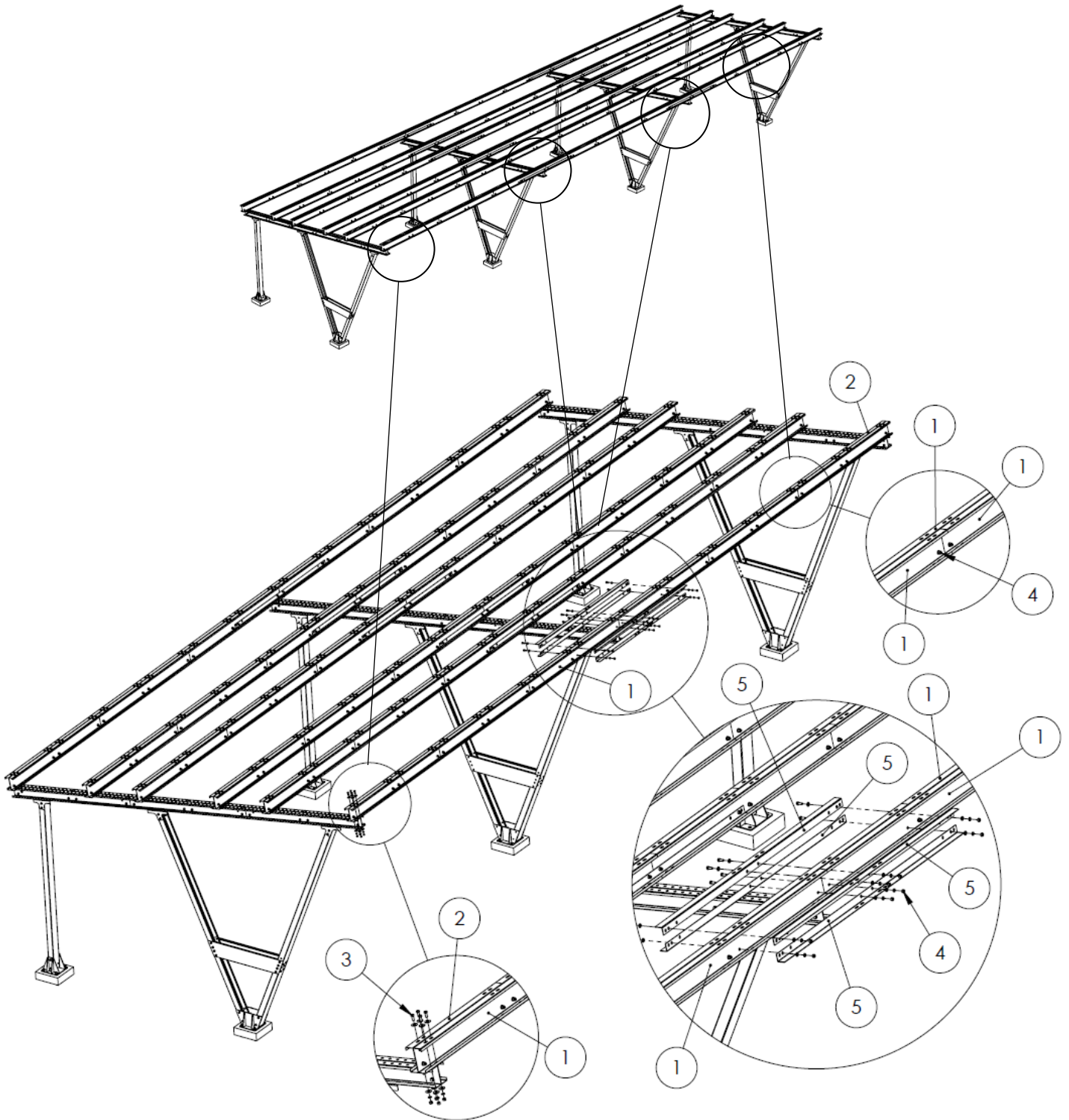

STEP 12



A 19 mm

1	M12 DIN 582	
2	Tension screw	
3	Carabiner 10x100	
4	DIN 6899B 6 mm	
5	U-BOLT CLAMP	
6	STEEL CABLE Fi 6	L=7,5 m
7	SET 3	
8	M12 DIN 580	

Instruction number
VICA-3x2_V1
Release date
26.07.2025

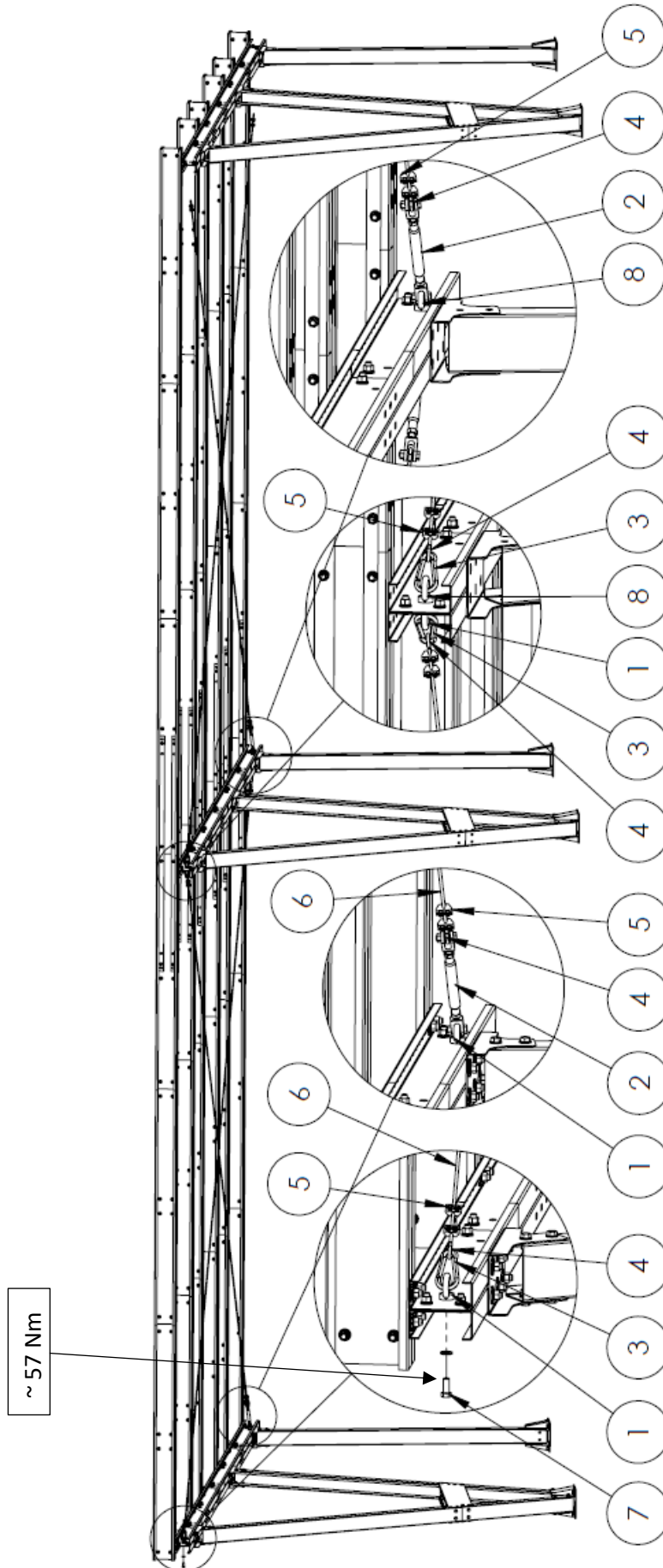



Instruction number
VICA-3x2_V1
Release date
26.07.2025

STEP 13

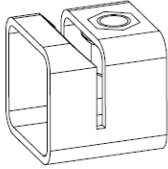
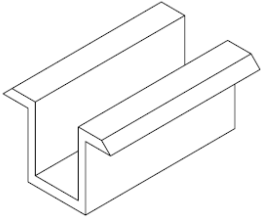
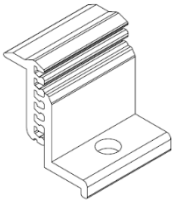

(HEX): 6 mm

1	ZU1	
2	CLAMP	
3	END CLAMP	
4	M8 DIN 127	
5	M8x40 DIN 912	

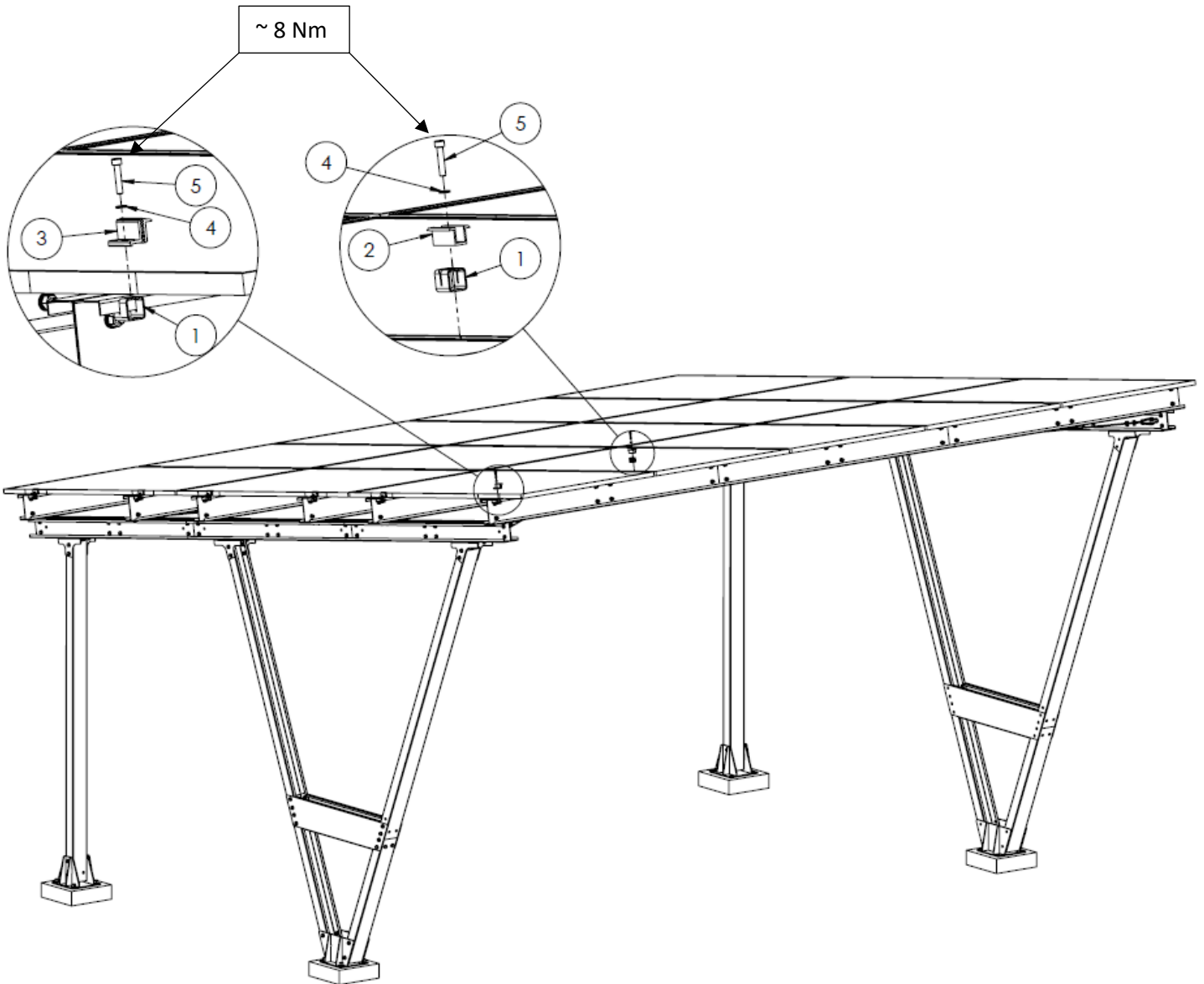

Instruction number
VICA-3x2_V1
Release date
26.07.2025



	VICA 3x2 cars 45 PANELS	MANUAL	WIND 28 m/s SNOW 1,6 kN/m²	Instruction number
				VICA-3x2_V1
				Release date
				26.07.2025

STEP 14* (OPTIONAL)





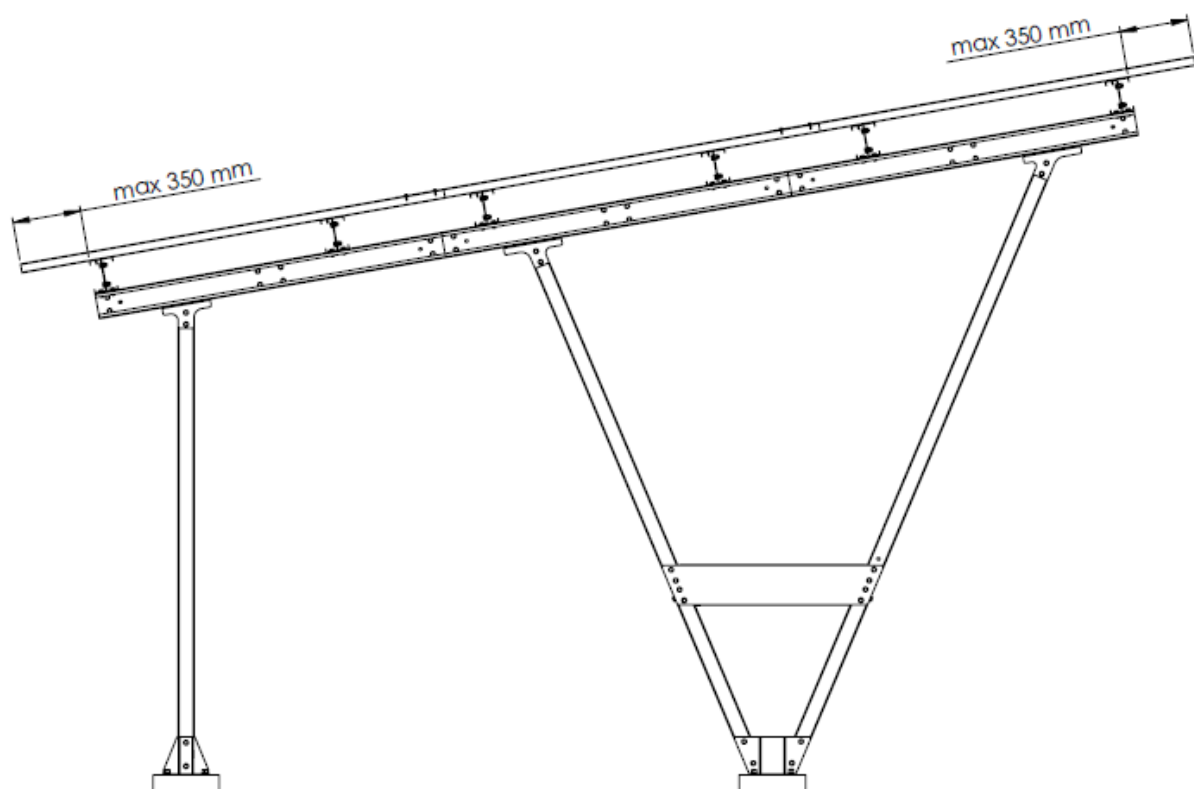



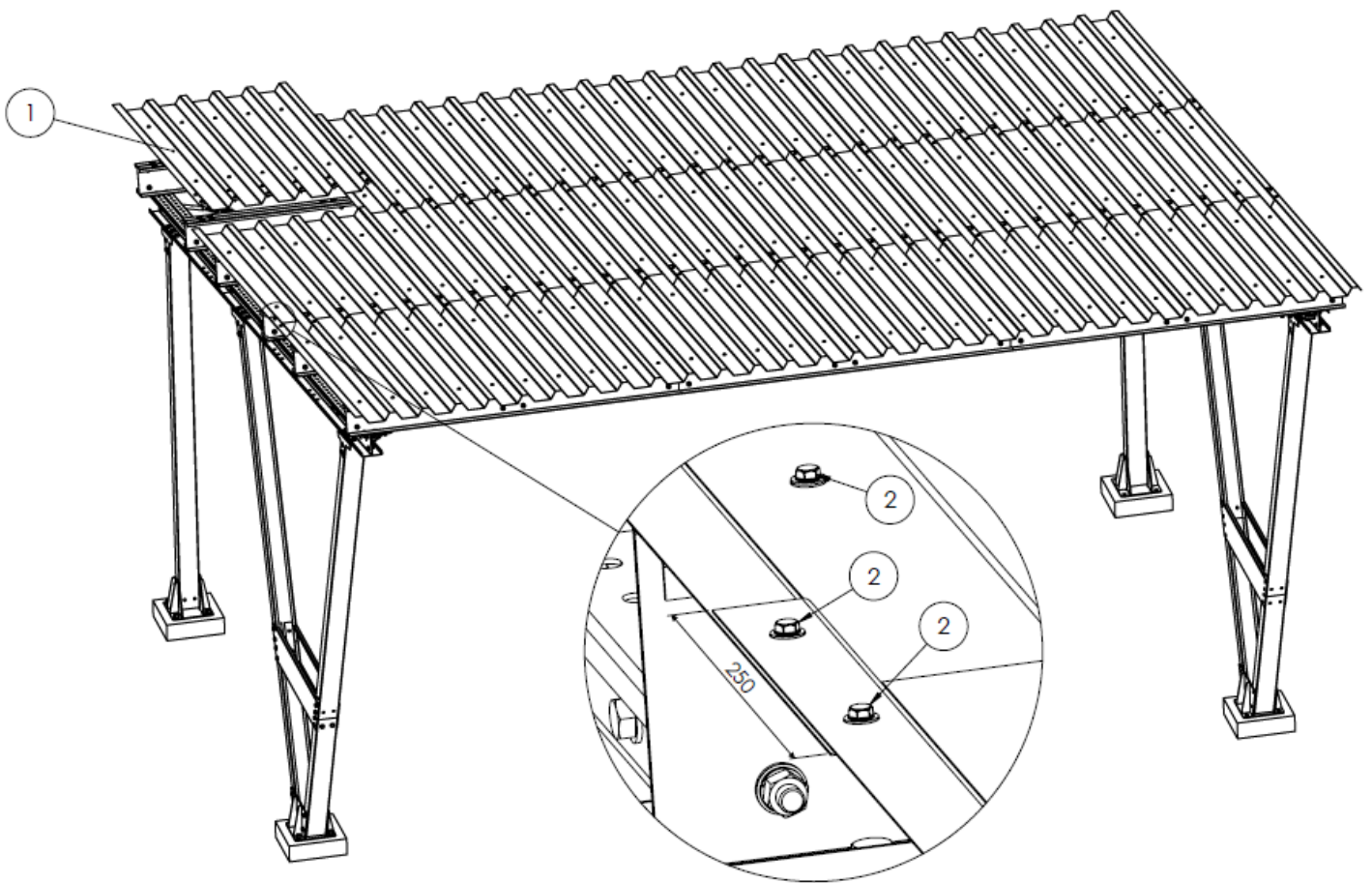





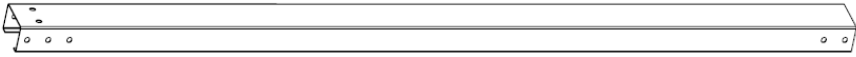

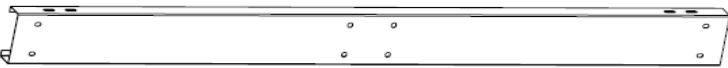
1	T45 1040x2200	
2	JF3-2-5,5x25 E16	

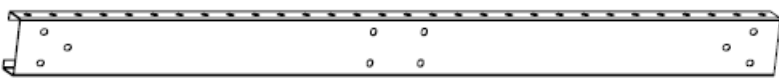

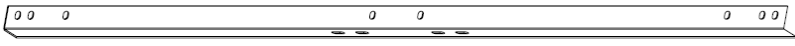



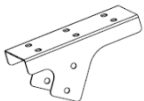
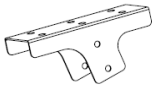
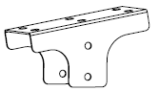





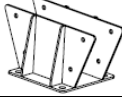



Instruction number
VICA-3x2_V1
Release date
26.07.2025



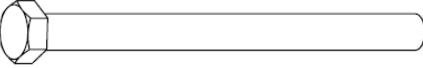







	VICA 3x2 cars 45 PANELS	MANUAL	WIND 28 m/s SNOW 1,6 kN/m²	Instruction number
				VICA-3x2_V1
				Release date
				26.07.2025

NR.		QUANTITY [pcs]	
		45 pannels	
CAR_IV_S01		4	
CAR_IV_S02		8	
CAR_IV_S03		8	
CAR_IV_P01		102	
CAR_IV_P02		12	
CAR_IV_R01		20	
CAR_IV_R02		8	
CAR_IV_WZ 01_v1		48	
CAR_IV_WZ02		12	
CAR_IV_L01		16	
CAR_IV_L02		8	
CAR_IV_W01		4	
CAR_IV_W02		4	
CAR_IV_W03		4	
CAR_IV_ST01		4	

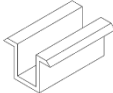
	VICA 3x2 cars 45 PANELS	MANUAL	WIND 28 m/s SNOW 1,6 kN/m²	Instruction number
				VICA-3x2_V1
				Release date
				26.07.2025

NR.			QUANTITY [pcs]	
			45 pannels	
CAR_IV_ST02			4	
M12 DIN 582			8	
M12 DIN 580			4	
M12 TENSION SCREW			6	
CARABINER 10x100			6	
DIN 6899B 6 mm			12	
U-BOLT CLAMP			24	
STEEL CABLE Fi 6	L=7,5 m		6	
M12x150 DIN 931			24	
CAR_IV_T01			24	
M12x30 DIN 933			868	
M12 DIN 9021			336	
M12 DIN 125			1388	
M12 DIN 127			876	
M12 DIN 934			872	







	VICA 3x2 cars 45 PANELS	MANUAL	WIND 28 m/s SNOW 1,6 kN/m²	Instruction number
				VICA-3x2_V1
				Release date
				26.07.2025

NR.		QUANTITY [pcs]	
		45 pannels	
ZU1		96	
CLAMP		84	
END CLAMP		12	
M8x40 DIN 912		96	
M8 DIN 127		96	
MANUAL		1	
CE MARKING		1	
DECLARATION OF CONFIRMITY		1	

.....
Packer's Signature

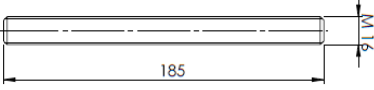
.....
Date

	VICA 3x2 cars 45 PANELS	MANUAL	WIND 28 m/s SNOW 1,6 kN/m2	Instruction number
				VICA-3x2_V1
				Release date
				26.07.2025

NR.	OPTIONAL	QUANTITY [pcs]
T45 1040x2200		48
JF3-2-5,5x25 E16		912
Threaded rod M16x185 8.8		36
DIN 125 A17 M16		36
DIN 127 M16		36
DIN 934 M16		36
R-KER-II RAWLPLUG		3

Not included in the standard set

.....

Packer's Signature

.....

Date

DECLARATION OF PERFORMANCE

No. SYNERGA 01/2021

- 1. Product** Construction Set:
CARPORT VICA_2x2 according to the specification dated
.....
- 2. Intended Use** In accordance with the assembly manual CARPORT VICA_3x2_V1
- 3. Place of Production** SYNERGA POLSKA
Ul. Ustronna 45
93-350 Łódź, Polska
- 4. Assessment and Verification System
of Performance Consistency:** System 2+
- 5. Harmonized Standard** EN 1090-1:2009+A1:2011
Notified Body TUV Thuringen Polska sp. z o.o. id: 2827
Certificate Number: 2827-CPR-PW01-1-1769-0311.24.00

6. Declared Performance Characteristics:

Essential Characteristics	Performance Properties
Construction Class	EXC2
Dimensional Tolerances	Class 1 according to EN 1090-2
Weldability	S350GD
Crack Resistance	NPD
Fatigue Strength	NPD
Load-Bearing Capacity	According to CARPORT VICA design
Deformation at Serviceability Limit State	According to CARPORT VICA design
Reaction to Fire	A1 (unpainted structure)
Fire Resistance	NPD
Cadmium and its Compounds Content	NPD
Radioactive Substances Content	NPD
Durability	In accordance with the CARPORT VICA design

The performance characteristics of the product specified above are consistent with the declared set of performance properties. This declaration of performance is issued in accordance with Regulation (EU) No 305/2011 under the sole responsibility of the manufacturer specified above.

.....
On behalf of the manufacturer
[Name, Surname, Position]

.....
Date and Place of Issue



2827

SYNERGA POLSKA Sp. z o.o.
Ul. Dolna 59
98-160 Sędziejowice 24
24
2827-CPR-PW01-1-1769-0311.24.00

EN 1090-1:2009+A1:2011

CARPORT VICA

Dimensional Tolerance: Class 1 according to EN1090-2,

Weldability: S350GD

Resistance to Brittle Fracture: NPD

Reaction to Fire: A1 according to EN 13501-1

Cadmium Emission: NPD

Radioactivity: NPD

Durability: In accordance with the CARPORT VICA design and specification issued on

.....

Structural Characteristics:

Structural Characteristics: NPD

Load-Bearing Capacity: Design and calculations according to EN 1993-1 No. CARPORT VICA

Fire Resistance: NPD

Fatigue Strength: NPD

Execution: According to EN 1090-2

Execution Class: EXC2